

Using Origin 8 from LabVIEW is Easy

Origin 8's improved COM support and powerful data analysis and graphing capabilities make it an ideal software for processing data acquired by LabVIEW. OriginLab provides a collection of custom LabVIEW sub-VIs that are shipped with Origin. LabVIEW users can incorporate these custom sub-VIs in their main LabVIEW application to communicate seamlessly with Origin. These sub-VIs take advantage of Origin's automation server classes and can be used for operations such as opening and closing communication with Origin, exchanging data back and forth between Origin and LabVIEW, and sending commands to Origin. The table below displays the kernel of the block diagram for three of the provided sub-VIs.

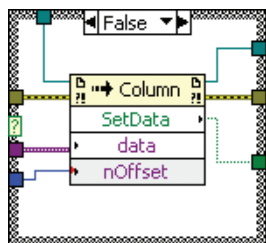

OA OA_Col-SetData
 This VI employs the SetData method of Origin's Column class to put an array of values into an Origin column object.

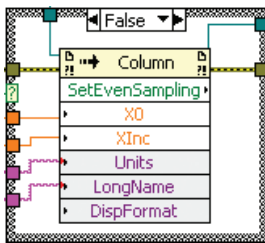

OA OA_Col-SetEvenSampling
 This VI sets the sampling interval of the data in an Origin column by using the SetEvenSampling method of the Column class.

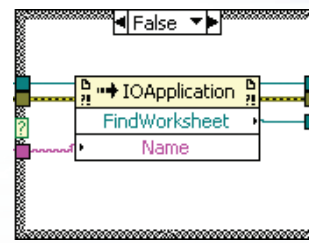

OA OA_FindWorksheet
 This VI utilizes the FindWorksheet method of the IOApplication class to select a specific Origin worksheet by its name.

Use Origin to Complement your DAQ Application

Sending data from LabVIEW to Origin is now very simple. In the simple DAQ VI below, only two Origin-specific sub-VIs are needed. The dynamic data output from any LabVIEW input source can be wired into an Origin sub-VI, just as simple as wiring that data to a LabVIEW graph object.

Post-processing data sent to Origin is very convenient. Origin has intuitive and interactive graph manipulation tools, such as zooming in and out of a region of data, selecting a region of data for analysis, not to mention the flexibility and ease of creating many different plots of the data.

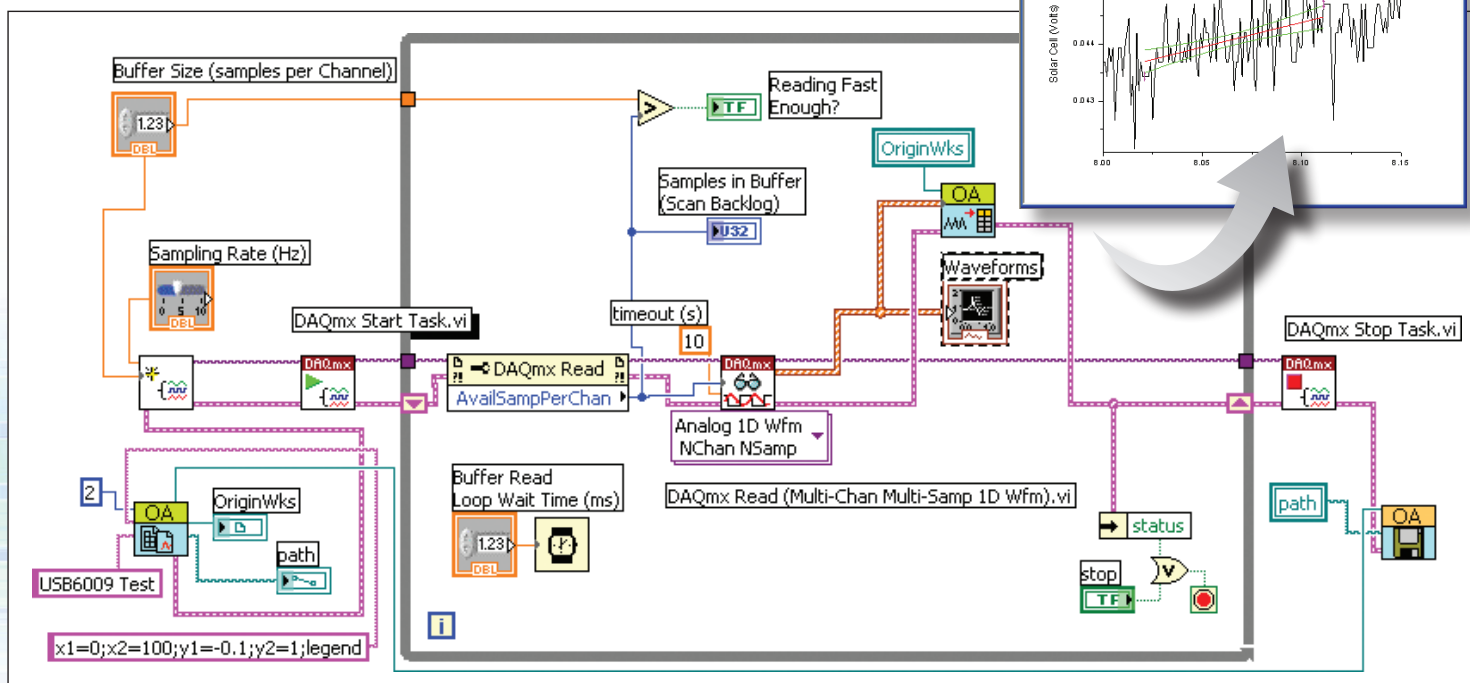

Harness the Power of Origin's Analysis Templates™

To best use the power of Origin, LabVIEW VIs can be created to push the acquired data directly into an Analysis Template in Origin, thus automatically updating analysis results and custom report sheets that are ready for presentation or printing.

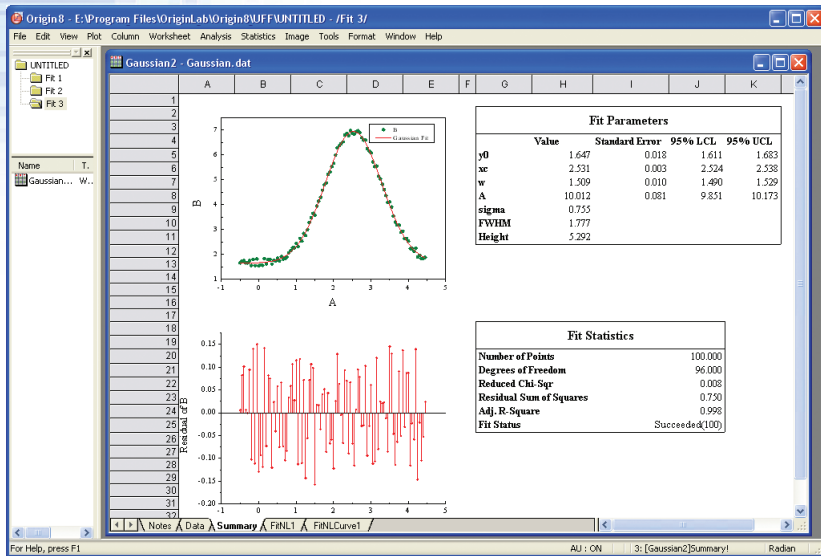
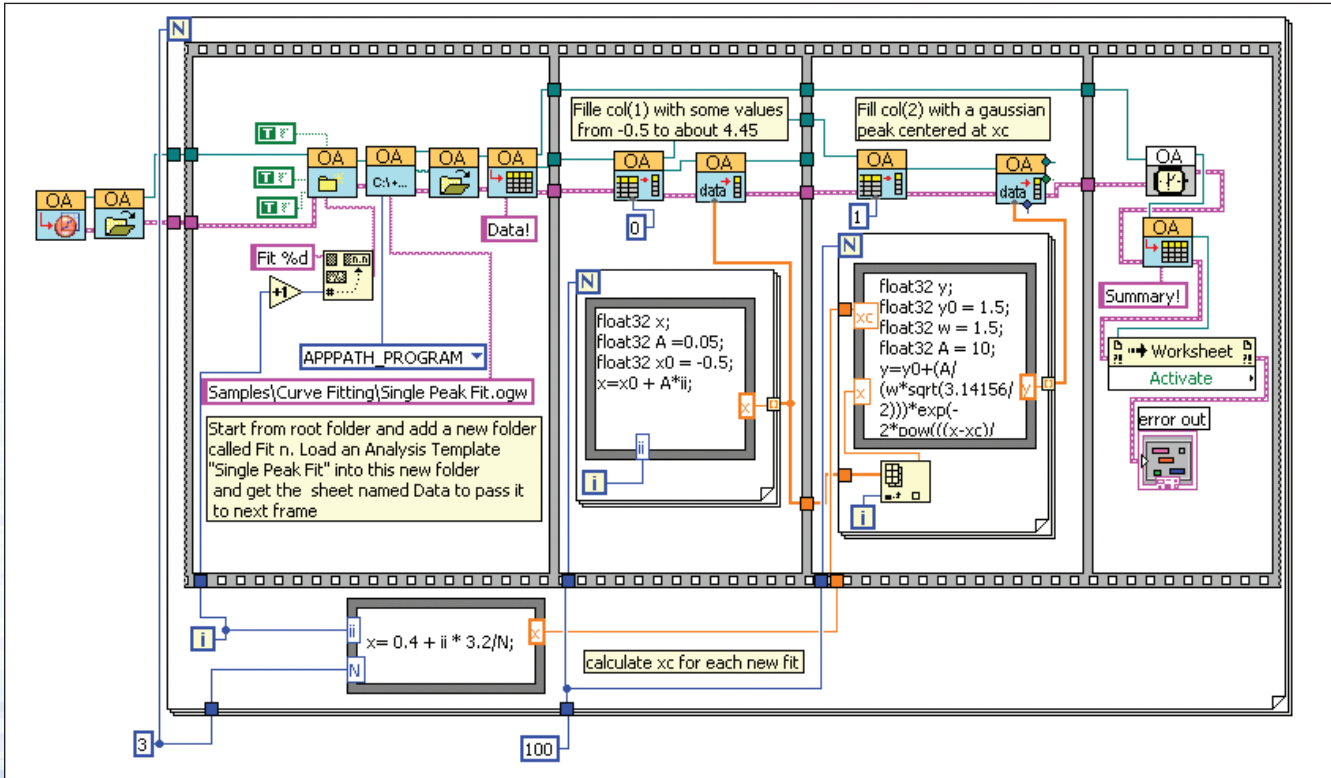

The VI diagram above demonstrates an example of how to perform batch analysis of multiple datasets using an Analysis Template in Origin.

In this example, the experimental data has been fitted to a Gaussian curve. The fitted curve, residuals and fit statistics are presented in a user-created report sheet.

Once the VI has executed, the Origin project will have separate subfolders for each dataset. Within each subfolder the Analysis Template will contain the raw data, the analysis results, and the custom report sheet ready for printing or exporting.

Other Sub-VIs Provided with Origin Include:

- OA_ConnectToOrigin: Initialize Origin connection.
- OA_PE_mkdir: Create new folder in the Origin workspace.
- OA_GetColumn: Get specific column in worksheet by column index.
- OA_Load: Load an Origin .opj file or .ogw file.
- OA_Col-GetData (numeric): Get a numeric array from a column.
- OA_Col-GetData (string): Get text array from a column
- OA_PlotWksCols: Plot a range of worksheet.



OriginLab Corporation
 One Roundhouse Plaza, Suite 303, Northampton, MA 01060 USA
 USA: 1-800-969-7720 □ INT'L: +1-413-586-2013 □ FAX: 1-413-585-0126
 EMAIL: info@originlab.com □ WEB: www.originlab.com

OriginLab and Origin are registered trademarks of OriginLab Corporation. All other brand and product names are trademarks of their respective owners.